

ENERGY PROFILES LIMITED

Cooling 101

Bob Bach, P.Eng.

Senior Consultant
Energy Profiles Limited



ENERGY PROFILES LIMITED

Outline

- Introduction
- Comfort Defined
- Cooling System Basics
- Cooling Efficiency
- Cooling Loads by Building Type
- Impact on Demand
- Typical A/C Units



ENERGY PROFILES LIMITED

Thermal Comfort

- Definition: the condition of the mind that expresses satisfaction with the thermal environment: it requires subjective evaluation

ASHRAE Standard 55, Thermal Environmental Conditions for Human Comfort



ENERGY PROFILES LIMITED

Ole Fanger – Technical University of Denmark

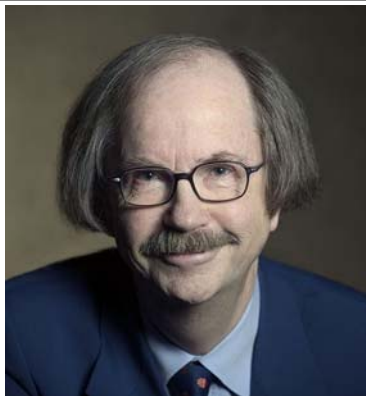

- Researcher on Thermal Comfort
- Developer of the unit of clothing insulation – the “clo”



ENERGY PROFILES LIMITED

Thermal Environmental Conditions for Human Occupancy

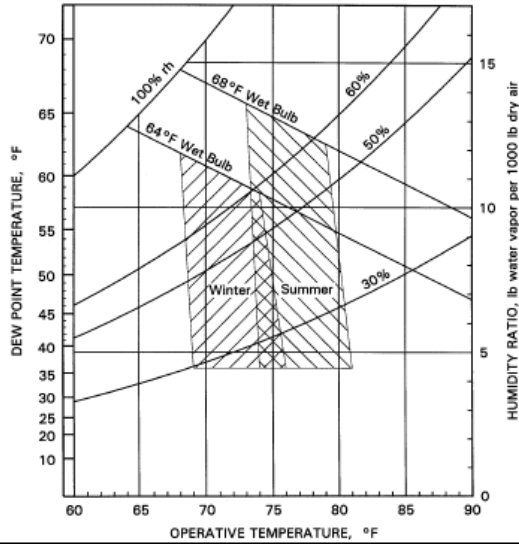

ENERGY PROFILES LIMITED

The Vapour Compression Refrigeration Cycle

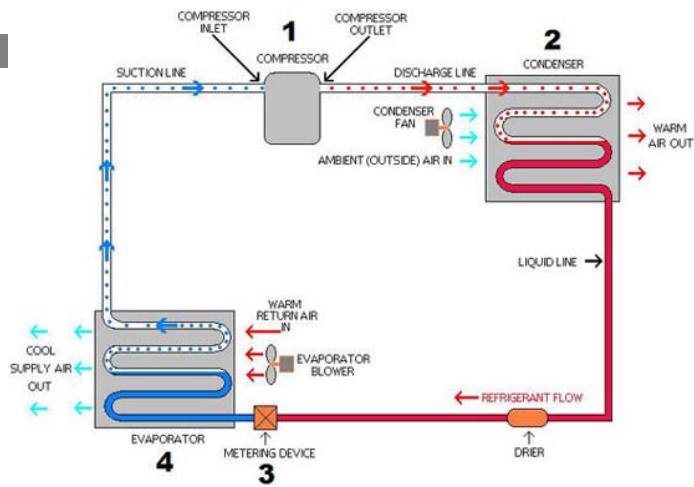



ENERGY PROFILES LIMITED

Vapour Compression Cycle - Pressures

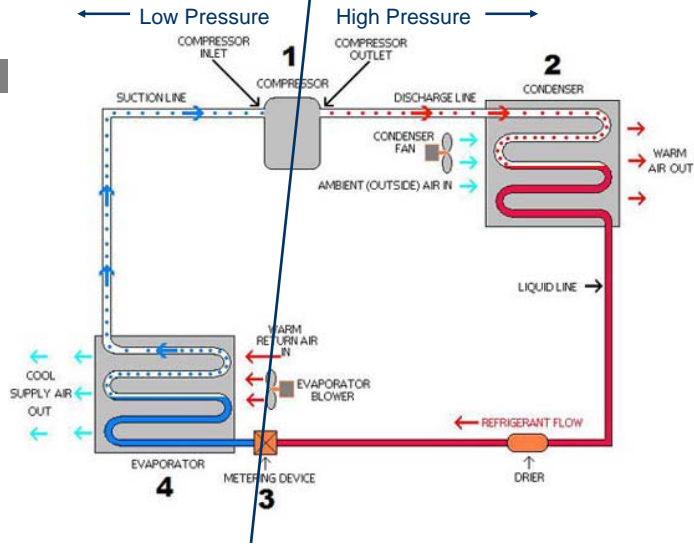

ENERGY PROFILES LIMITED

Vapour Compression Cycle - Configuration

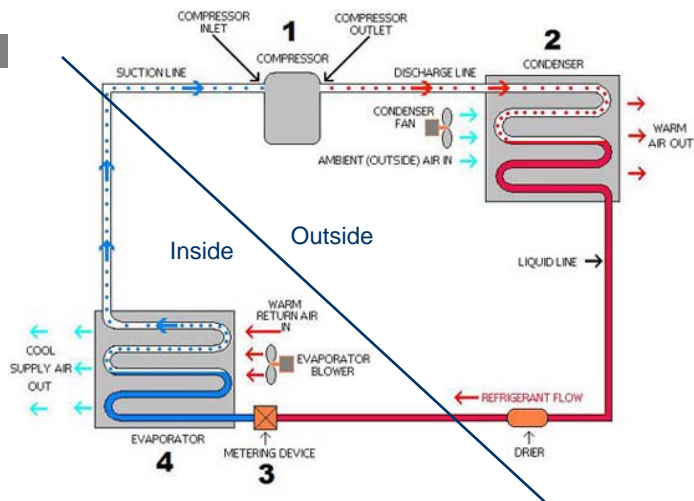



Output Capacity

- Output is measured in either:
 - Tons of cooling (1 ton = heat required to melt 1 ton of ice in 24 hrs. = 12,000 Btu/hr)
 - Btu/hr (British thermal units/hr. 1 Btu = amount of heat required to heat 1 pound of water through 1 degree F)
 - Kilowatts (1 kilowatt = 3412 Btu/hr)



Vapour Compression Cycle - Electricity

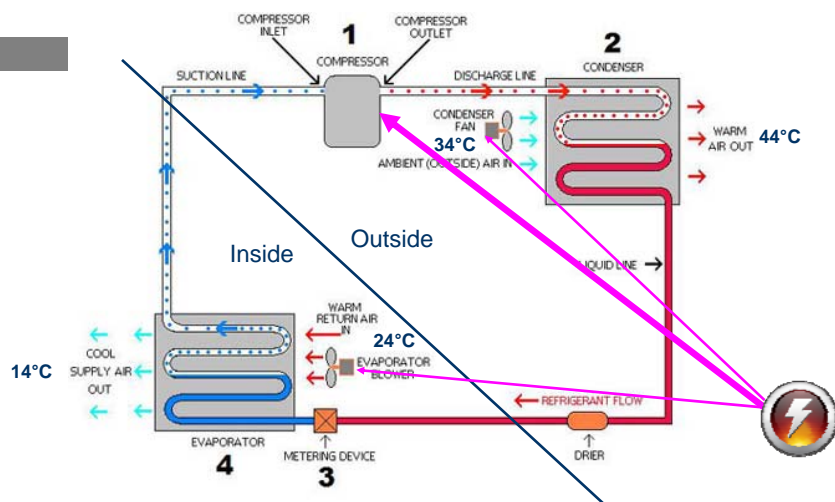

Vapour Compression Cycle – Efficiency

- EER – Energy Efficiency ratio =
$$\frac{\text{Cooling Output (Btu/hr)}}{\text{Electrical Input (watts)}}$$
- SEER – Seasonal Energy Efficiency ratio =
EER (modified by test & calculation)
- IPLV – Integrated Part Load Value =
EER (modified by calculation)

What Contributes to Cooling Load?

- Solar Heat Gain (sensible)
 - Windows
- Thermal Transmission Heat Gain (sensible)
 - Windows, doors, walls, roof
- Ventilation & Infiltration Heat Gain (sensible & latent)
- Internal Heat Gain (sensible & latent)
 - People
 - Lights
 - Appliances/office equipment/other equipment



Commercial Building Cooling Characteristics

- In general:
 - Buildings with high internal loads (people, lights, plug load) have higher base cooling loads, e.g. Office
 - Buildings with lower internal loads have cooling loads that are driven mainly by outdoor weather conditions, e.g. MUR



What's the Impact of Cooling Load on Building Energy Consumption?

Annual Energy End-Use Share for Selected Building Types							
Energy End-Use	Condo	School	Office	Health-care	College/University	Food Sales	Retail
Space Cooling	5%	3%	6%	6%	10%	2%	4%
Space Heating	46%	58%	45%	52%	46%	24%	59%
Water Heating	14%	11%	9%	14%	12%	1%	1%
Auxiliary Equipment	15%	3%	8%	5%	10%	4%	2%
Auxiliary Motors	11%	13%	14%	11%	12%	2%	10%
Lighting	9%	12%	18%	12%	10%	23%	24%
Refrigeration	0%	0%	0%	0%	0%	44%	0%



ENERGY PROFILES LIMITED

What's the Impact of Cooling Load on System Load Shape?

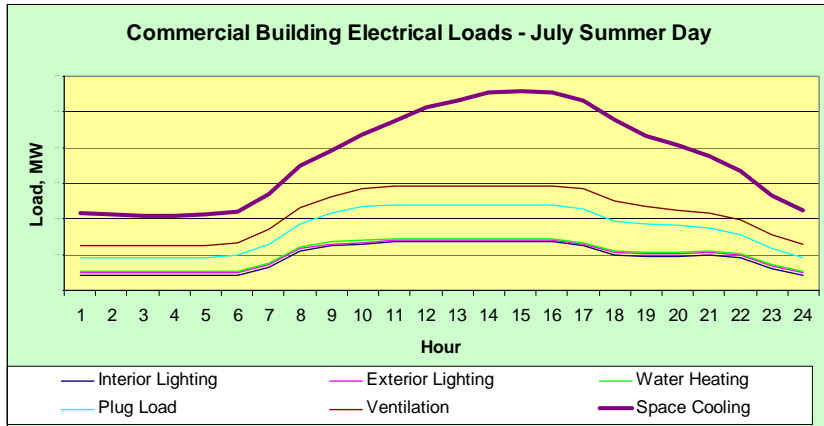

ENERGY PROFILES LIMITED

Types of Cooling Units - Residential





ENERGY PROFILES LIMITED

Types of Cooling Units - Residential



ENERGY PROFILES LIMITED

Types of Cooling Units - Rooftop



Types of Cooling Units – Large Split Systems



Ductless Systems





ENERGY PROFILES LIMITED

Centrifugal Chillers



ENERGY PROFILES LIMITED

Component Options - Refrigerants

- Traditional Unitary A/C refrigerant – R-22 (ODP = 0.055)
- New Unitary A/C refrigerant – R-410a (a zeotrope* of R-32/105 (50/50): ODP = 0)
- Former automotive A/C refrigerant – R-12 (ODP = 1.0)
- Current automotive A/C refrigerant – R-134a (ODP = 0)
- Traditional centrifugal chiller refrigerant – R-11 (ODP = 1.0)
- Current centrifugal chiller refrigerant - R-134a (ODP = 0)

*zeotrope: a blend comprising multiple components of different volatiles that, when used in refrigeration cycles, change volumetric composition and saturation temperatures as they evaporate or condense at constant pressure



Frank Sherwood Rowland

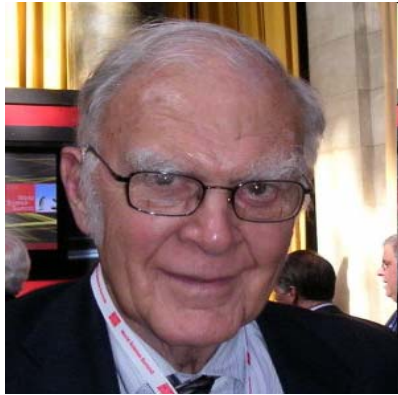

- Discovered that CFCs contribute to ozone depletion
- Received the 1995 Nobel Prize in Chemistry for this research



Component Options

- Compressors:
 - Reciprocating (hermetic; semi-hermetic) 1 – 50 tons
 - Scroll (2 to 30 tons)
 - Screw (50 tons +)
 - Centrifugal (100 tons +)
 - Single speed, 2-speed, variable speed
- Evaporators
 - Refrigerant to air
 - Refrigerant to water (chillers)
- Evaporator Fans & Fan Motors:
 - Single speed – dual speed – variable speed
 - Constant volume – variable volume
 - Direct drive – belt drive



Component Options

- **Condensers**
 - Air cooled
 - Water cooled (connected to a cooling tower)
 - Evaporative (uses water sprayed on condenser)
- **Condenser Fans & Fan Motors**
 - Constant speed
 - Variable speed
 - Propeller type
 - Centrifugal type (indoor condensers)
- **Expansion Devices**
 - Thermal expansion valve
 - Capillary tube
 - Orifice



Component Options

- **Economizers**
 - Air side (Rooftop units)
 - Water side (chillers)
- **Heat & Energy Recovery Ventilators**
 - Can be easily added to rooftop units
 - Can be stand alone types
- **Zone Control Systems**
 - Provides closer temperature control



Equipment Efficiency Improvement

Application	Equipment Type	Capacity Range, tons	Efficiency Type	Efficiency Range by Year	
				1995	2009
Residential	Unitary Split System	1 to 5	SEER	7.0 to 8.0	13.0 to 21.0
Small Commercial	Unitary Single Package	6 to 20	EER	6.0 to 7.0	10.0 to 15.0
Large Commercial	Unitary Single Package	21 to 120	EER	7.0 to 8.0	11.0 to 14.0
"	Centrifugal	100 +	kW/ton	7.5 to 9.0	4.5 to 5.5



Questions?

bback@energyprofiles.com